

NOTES

1. The access and visibility splays' dimensions to be as conditioned in granted planning permission.
2. It is an OFFENCE to carry out works within the public highway without the permission Suffolk County Council as the Highway Authority.
3. Bound surfacing to extend into the site 5m from channel of carriageway. Any access gates are to be 5m minimum from the edge of carriageway and to opening inwards, away from the highway.
4. To prevent private surface water from entering the highway, the highway boundary is to be the highpoint; where this is not possible, positive drainage is required within private land with a bullnose kerb, as described in detail A.
5. For a domestic access serving a single or two dwellings, an application for a Dropped Kerb is to be made. For a site that serves over three dwellings or a commercial premises, a Minor Works Application is required.
6. Applicants are reminded that utility apparatus may be affected by the proposed works and it is a legal requirement that they or the contractor contacts the owner of the apparatus prior to work starting.

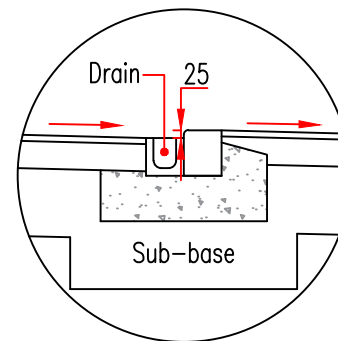

DETAIL A
See note 4

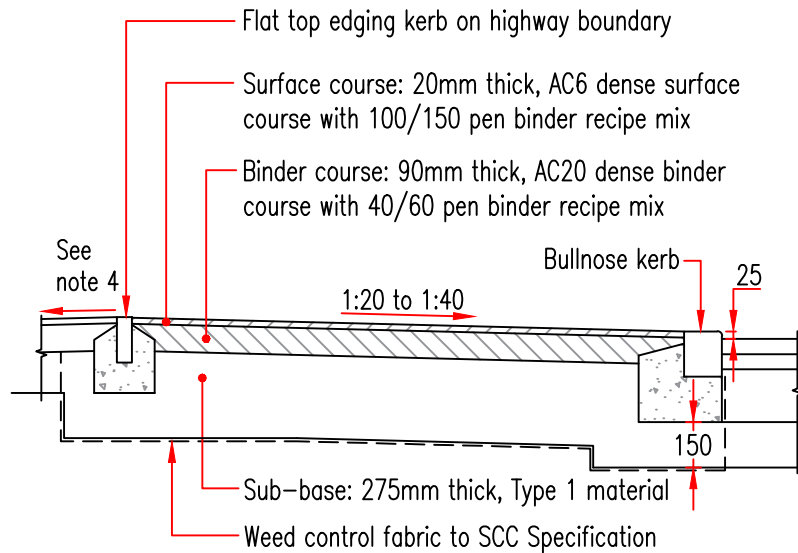

Growth, Highways & Infrastructure
Suffolk County Council
Endeavour House
8 Russell Road
Ipswich
Suffolk IP1 2BX

DRAWING TITLE
DEVELOPMENT MANAGEMENT
DOMESTIC VEHICULAR ACCESS LAYOUT
NO EXISTING FOOTWAY OR KERBLINE

REV.	DESCRIPTION	CHECKED	DATE

ORIGINATOR	INIT.	DATE	PROJECT TITLE	
RY	RY	07/2024	STANDARD CONSTRUCTION DETAILS	
CHECKER	SH	07/2024	SCALE	DATE
RY	RY	07/2024	N.T.S.	JUL. 2024
DESIGNER	TK	07/2024	DRAWING No.	
TK	TK	07/2024	DM-000-01	
REVIEWER				