

NOTES

1. Tactile paving to be 400 x 400 x 50mm thick laid on 25mm Class 1 mortar on 150mm ST1 concrete on primary/secondary road and, Type 1 sub-base on tertiary/shared surface road.
2. Red paving to be used at controlled crossings. Buff or contrasting colour other than red to be used at uncontrolled crossings.
3. Kerb face to be 6mm; No greater than 12mm.
4. Tactile paving to be laid such that the domes are in line with the direction of pedestrian travel.
5. Tactile crossing width to be 2m minimum.
6. Gullies are not to be within the crossing area and need to be positioned upstream.

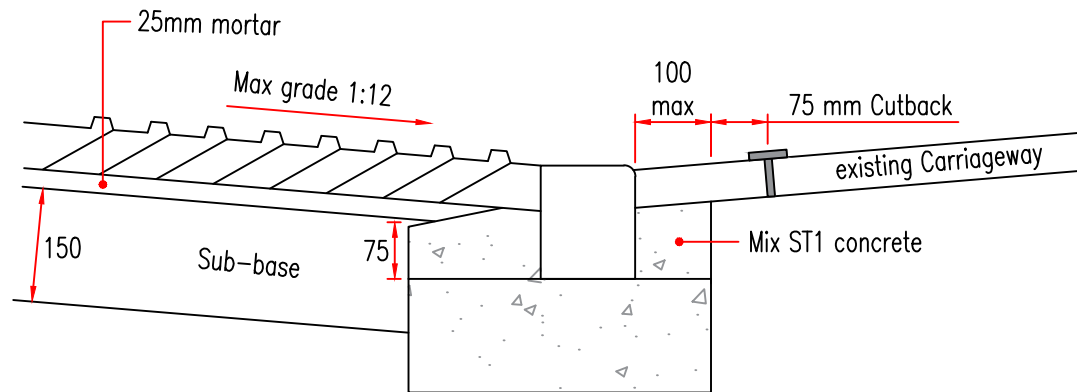

Growth, Highways & Infrastructure
Suffolk County Council
Endeavour House
8 Russell Road
Ipswich
Suffolk IP1 2BX

DRAWING TITLE
KERBS, FOOTWAYS, CYCLEWAYS AND PAVED AREAS
TACTILE PAVING GENERAL ARRANGEMENT

REV.	DESCRIPTION	CHECKED	DATE

INIT.	DATE	PROJECT TITLE	
RY	07/2024	STANDARD CONSTRUCTION DETAILS	
SH	07/2024	SCALE	DATE
RY	07/2024	N.T.S.	JUL. 2024
TK	07/2024	DRAWING No.	
		DM-1100-19	