

NOTES

1. All ducting between chambers and signal poles to be 100mm dia. orange in colour and clearly marked "Traffic Signals". The duct is to be laid with the working face upwards.
2. All 100mm dia. ducting to be smooth walled, inside and out, with a minimum wall thickness of 5mm.
3. Pole housing unit to be sunk to a suitable level to allow pole planting depths between 650 and 700mm.

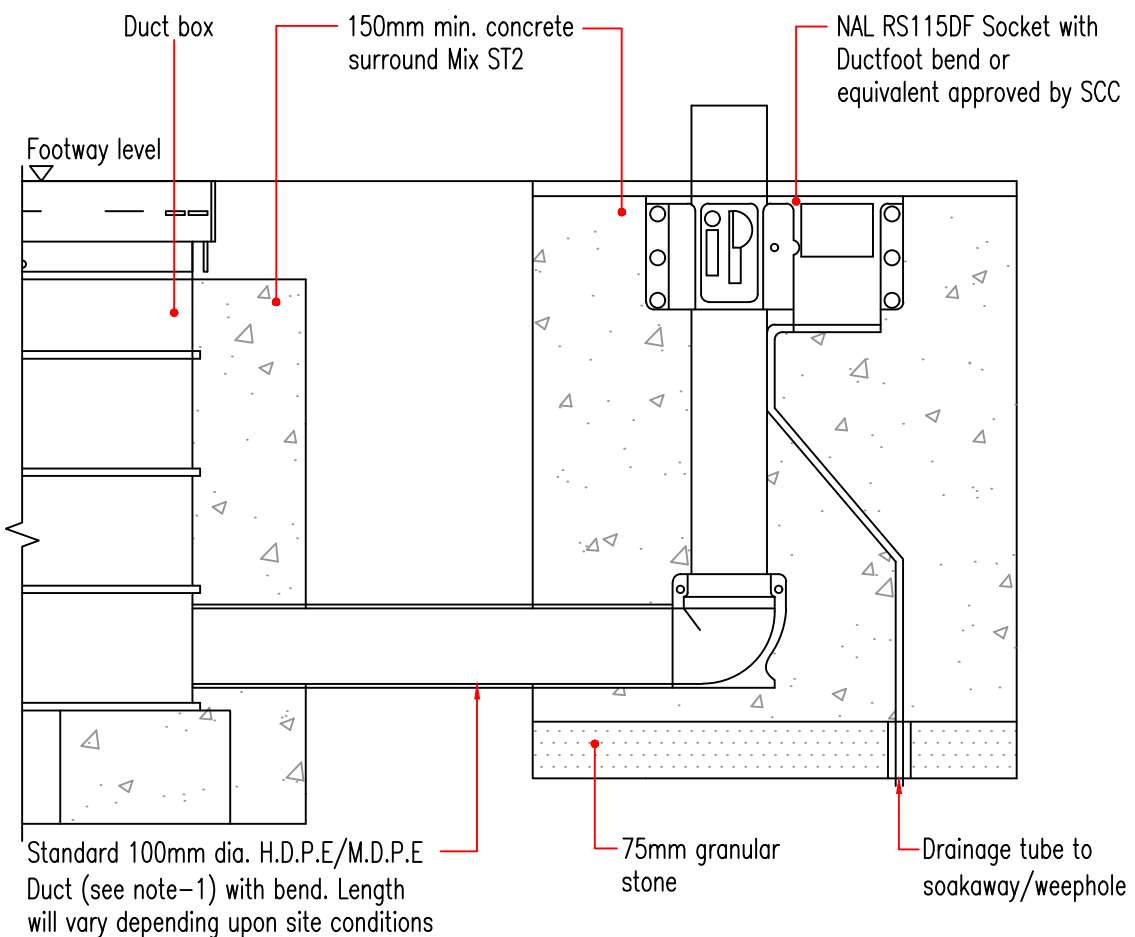

Growth, Highways & Infrastructure  
Suffolk County Council  
Endeavour House  
8 Russell Road  
Ipswich  
Suffolk IP1 2BX

**DRAWING TITLE**  
DRAINAGE AND SERVICE DUCTS  
REMOTE SIGNAL POLE UNIT "NAL" SOCKET

REV.	DESCRIPTION	CHECKED	DATE

ORIGINATOR	INIT.	DATE	PROJECT TITLE	
RY	RY	08/2024	STANDARD CONSTRUCTION DETAILS	
CHECKER	SH	08/2024	SCALE	DATE
SH	SH	08/2024	N.T.S.	AUG. 2024
DESIGNER	RY	08/2024	DRAWING No.	
RY	RY	08/2024	DM-500-15	
REVIEWER	TK	08/2024		
TK	TK	08/2024		